

Over
45 Years of
Service Excellence



Pumping and Water Filtration Solutions

www.asw.co.za



GROUP OF COMPANIES

ASW has been in existence since 1979 and was founded by the late Mr A Wischnewski and is still a family owned business. The company was predominantly involved in the importation of hydraulics and mechanical equipment for the Mines and Petrochemical industry and is still involved in the supply of mechanical and rotating equipment to this industry.

In 1986 ASW moved into its own premises in Johannesburg which is now the Head Office of the group.

Our strong presence in the water and waste water industry in the early 1990's resulted in the establishment of a water treatment division. This division focuses on the supply of equipment into the water industry as well as managing and completing turnkey projects for potable water treatment plants. ASW has also been involved in refurbishments, building complete new plants and numerous installations within the water and waste water industry.

Majority of our sales / business is generated by international organisations in South Africa and Africa.

Our customers are mainly drawn from the following markets:



PETRO CHEMICAL



WATER & WASTEWATER



PAPER & PULP



FOOD, BEVERAGE AND PHARMACEUTICAL



CHEMICAL



MINING



SUGAR



POWER



STEEL





“We strive to provide quality service and quality products at all times.”

This mission statement sums up the ethos, which forms the foundation for ASW’s business practice. ASW’s business is built on supplying the quality service that the client expects. The company’s on-time deliveries are legendary and are a benchmark in the industry.

Before accepting an order, ASW’s engineers will always advise the best system or component, and this advice will be either in-house or from overseas expertise.

ASW comprises of three specific divisions

- 1. Rotating Equipment**
- 2. Water Filtration and Equipment**
- 3. Engineering and Fabrication**

The first two divisions are all directly involved in the marketing and sales of their products, and the engineering division supports the two marketing divisions by:

- Design and development of new systems
- Design, installation and commissioning of turnkey projects
- Manufacturing and construction of systems and components
- Repair, servicing and testing the various products
- Quality assurance

ASW has been audited by various large organisations in the Petro-Chemical, Paper and Chemical industries and has been placed on their vendors list for the supply and manufacture of systems and components.

ASW keeps a large stock of spares to complement the range of standard equipment sold by the company.

Looking for Sensible Engineering Solutions?

You’ll find them at ASW, and if you do not see what you are looking for in this brochure do not hesitate to contact us at our head office in Randburg.



Level 2 Contributor
51% Black Ownership



ROTATING EQUIPMENT

Leistritz

PUMP TECHNOLOGY

**Internal Gear, Lobe and Screw Pumps (Also to API 676)
Specialising in Hot Fuel Oil Pumps**

Capacity \leq 1200 m³/hr
Head \leq 36 MPa
Temperature \leq 320°C

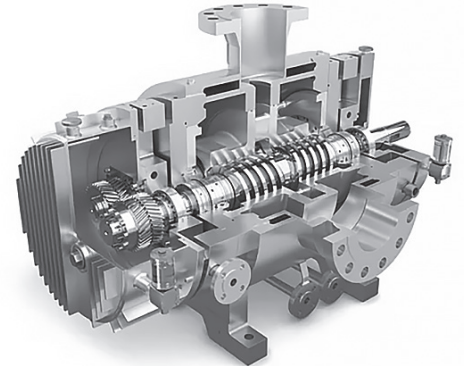

 **NOVA ROTORS**[®]
Progressing cavity pumps

Progressive Cavity Pumps

Capacity \leq 500 m³/hr
Pressure \leq 7200 KPa
Temperature \leq 200°C

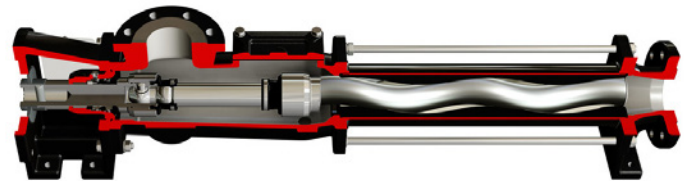

PCM

keep it moving

Peristaltic Pumps

Capacity \leq 68 m³/hr
Pressure \leq 1500 KPa
Temperature \leq 150°C



ROTATING EQUIPMENT



Plastic Chemical Norm, End Suction Pumps

Capacity \leq 200 m³/hr
Pressure \leq 700 KPa
Temperature \leq 0 to 100°C

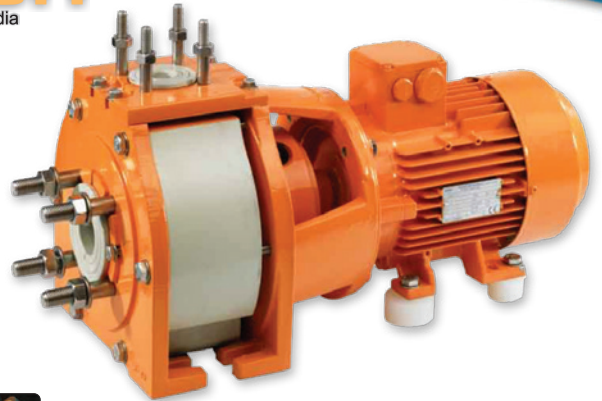

Sealless Canned Motor Pumps (Also to API 685) Including Refrigeration Pumps

Capacity \leq 1200 m³/hr
Head \leq 10 MPa
Temperature \leq -120 to +480°C

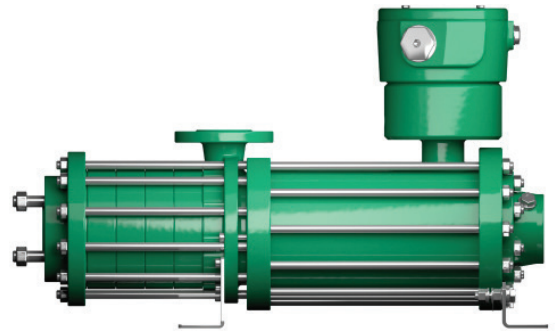

Chemical Process Pumps Standard Centrifugal, Magnetic Drive Pumps (Also to API 610 / 685)

Capacity \leq 1200 m³/hr
Head \leq 400 KPa
Temperature \leq -120°C to 400°C

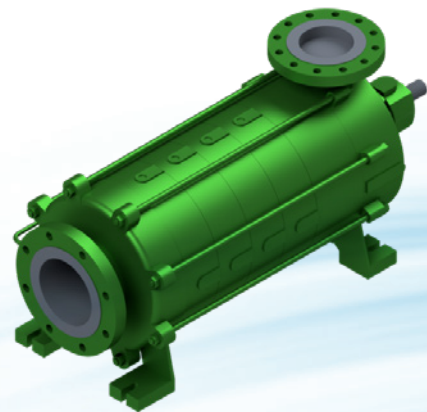

ROTATING EQUIPMENT

ProMinent®

Process and Piston / Diaphragm Dosing Pumps

Capacity ≤ 10 000 l/hr
Pressure ≤ 400 MPa
Design ≤ According API 675



BSK 
BSK Fluid Technology LLC.

Air Driven Pumps

FDA Compliant Food Grade
Range from 1/4" to 3"
Handles Larger Particles
Handles High Viscosity

Suction Capacity ≤ 903 L/m
Pressure ≤ 830 KPa



FINDER POMPE

Blowers

Suction Capacity ≤ 7230 m³/hr
Pressure ≤ 1000 m.bar
Temperature ≤ 130°C



ROTATING EQUIPMENT

Atlas Copco

Diesel Driven Dewatering Pumps

Delivery Capacity ≤ 2200 m³/hr
Pressure ≤ 800 KPa
Temperature ≤ 70°C

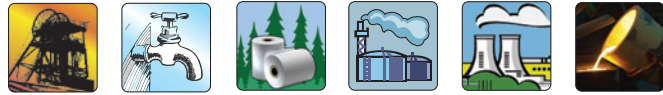

ASW WATER PUMPS

CENTRIFUGAL PUMPS FOR LOW TO MEDIUM HEADS AND CAPACITIES AS REQUIRED.

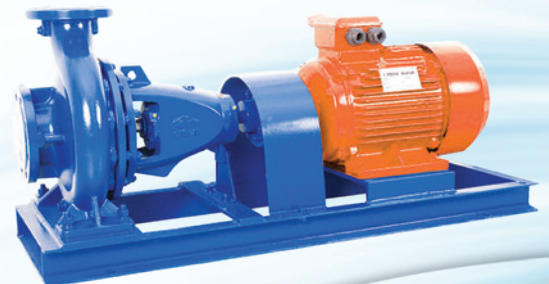
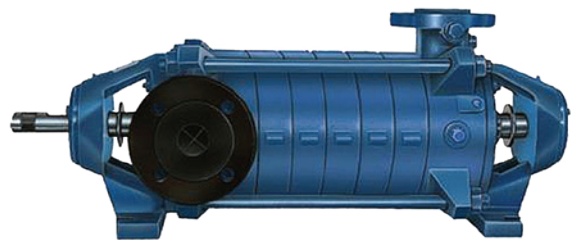

FILTRATION

Water filtration and water treatment plants designed, built and refurbished by ASW Group of Companies



Filter Floors

Monolithic floor installation or component supply for sand filter and gravity feed construction.



Filter nozzles and distribution systems
Available in many materials of construction suitable for cation, anion, resin exchange and filtration plants.

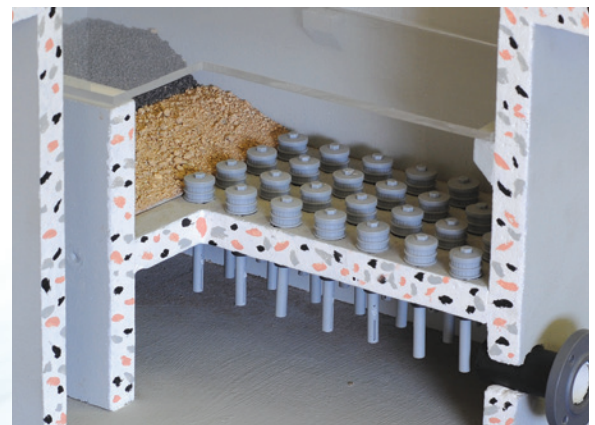

FILTRATION



Fully automatic self-cleaning in line filters.

Flow ≤ 320 m³/hr
Flange size ≤ 36" (900mm)

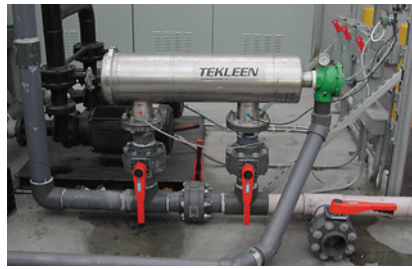
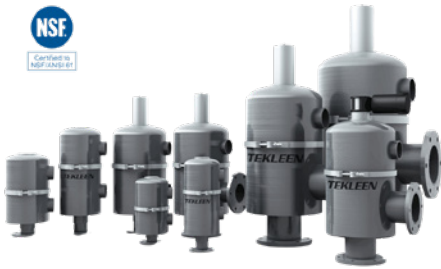

Mobile Containerized Potable Water Treatment Systems

We design, produce, install and operate systems for water treatment and filtration. Our systems have been verified and tested as a high-quality solution for water treatment for a wide spectrum of international clients.



Application:

Mobile containerized water treatment plant with various capacities. High turbidity removal and bad colour from spring water. Also removal of bacteria and algae.

Stationary Water Treatment Plants



Application:

Production of drinking water from a river. Also containerised with a total capacity from 1ML per day.



ASW SERVICES

MECHANICAL WORKSHOP



In-house repairs to our range of products and any brand of rotating equipment including hydraulics.

Strip, inspect, quote, repair / assemble and test.

SERVICE DEPARTMENT



24 Hour on site repairs and servicing of our products and all types of rotating equipment.

On site maintenance and inspection contracts for extended periods can be negotiated with clients.

MACHINING WORKSHOP



Precision machining for one-off or high volume quantities can be done.



OUR CUSTOMERS



sappi

FOSKOR

ArcelorMittal



HEINEKEN



exxaro
POWERING POSSIBILITY



ThyssenKrupp

WATERCARE INNOVATIONS
building long term partnerships



Eskom

samancor

Nampak
quality distinction



ESKORT
Life's Delicious

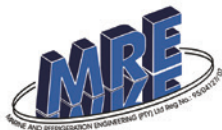

omnia
NUTRIOLOGY



FIRST QUANTUM
MINERALS

Tongaathulett

HEINEKEN

ABInBev

AngloAmerican



ASTRON
ENERGY

Thai Union

elementsix™
DE BEERS GROUP





For further information contact ASW at:

**ASW Head Office
Strijdom Park
Johannesburg
South Africa
Tel: +27 (0) 11 793 1330
e-mail: sales@asw.co.za**

www.asw.co.za